

Top View

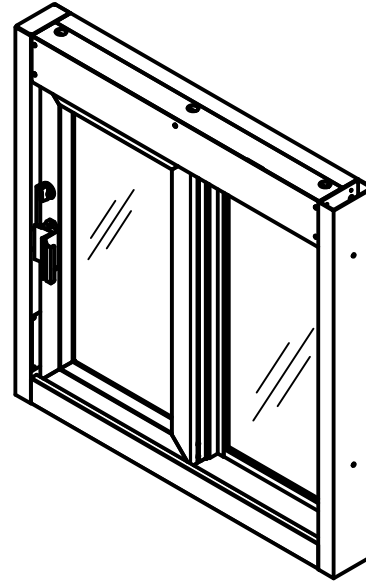

Interior Front View

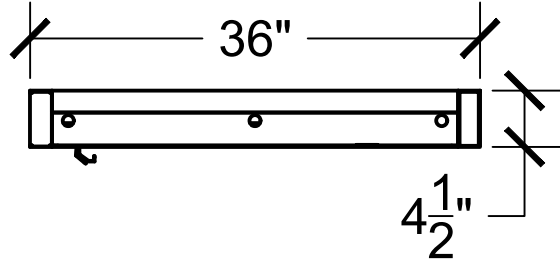
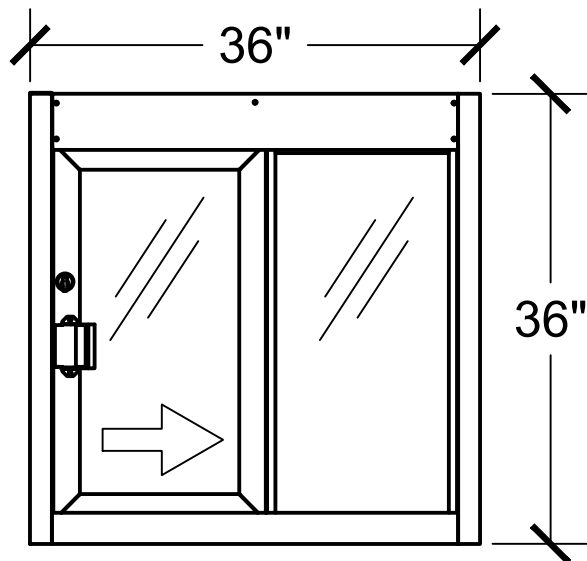

Side View

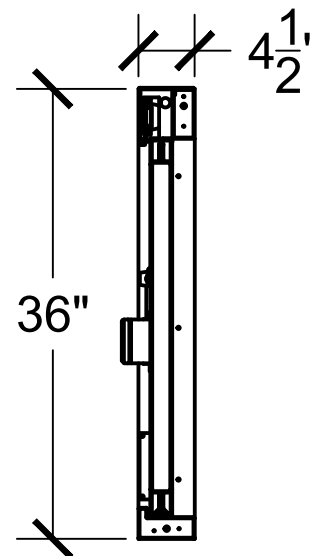

PLEASE SELECT:

1. FRAMING:

- Aluminum
- UL Rated Alum

2. FRAME COLOR:

- Bronze Anodized
- Clear Anodized

Other: _____

3. GLAZING:

- 1/4" Tempered
- 1" Insulated
- 3/4" Poly - L1
- 1-1/4" Acrylic - L1
- 1-1/4" Poly - L3
- 1-1/4" Acrylic - L3

- Storm Impact Low-E

Other: _____

Key Notes

Unit:

SC-3030 (LEFT)

Actual Dimension:

36"(W) x 36"(H)

Rough Opening:

36 3/8"(W) x 36 3/8"(H)

Service Opening:

14 1/2"(W) x 29"(H)

Engineer Notes

Date drawn: 5/27/2020

Drawn by: Avasquez

File name: SC-3030.dwg

Page: 1 of 1

Scale: 1:16

NOTE: THIS DRAWING EMBODIES A CONFIDENTIAL PROPRIETY DESIGN ORIGINATED AND OWNED BY QUIKSERV CORP., AND IS SUBMITTED UNDER A CONFIDENTIAL RELATIONS ALL PATENT, MANUFACTURING, SALE RIGHTS REGARDING THE SAME ARE RESERVED EXCEPT TO THE EXTENT RIGHTS ARE EXPRESSLY GRANTED TO OTHERS. THE RECIPIENT AGREES BY ACCEPTING THESE DRAWINGS NOT TO SUPPLY OR DISCLOSE ANY INFORMATION REGARDING THEM TO ANY UNAUTHORIZED PERSONAL.

SIGNATURE: _____

DATE: _____

Top View

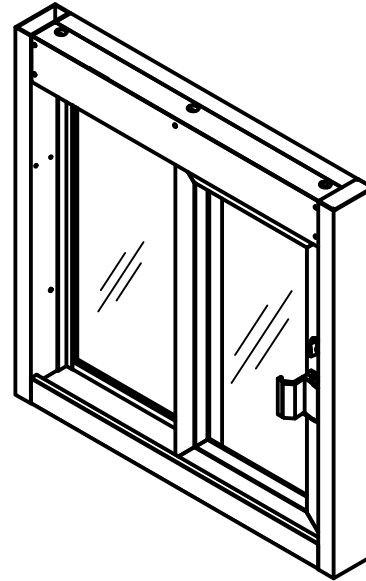
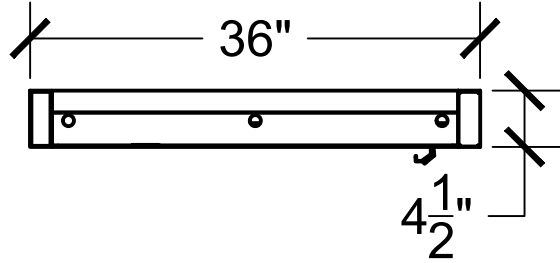

Interior Front View

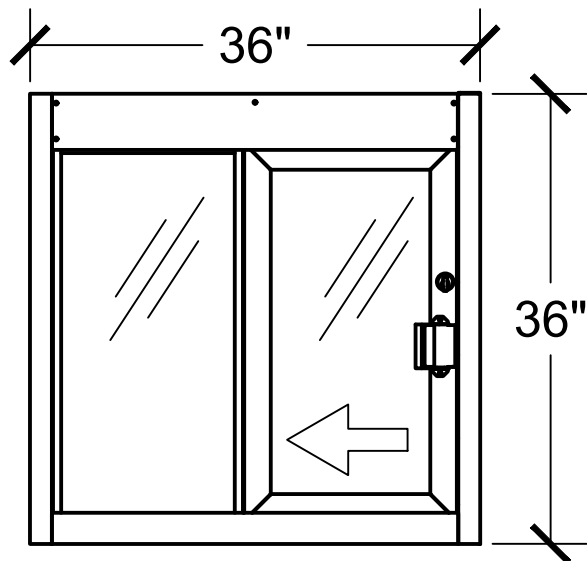

Side View

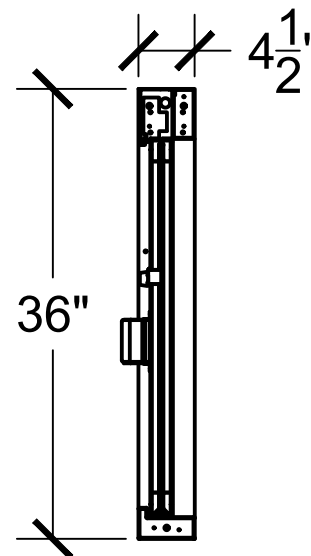

PLEASE SELECT:

1. FRAMING:

- Aluminum
- UL Rated Alum

2. FRAME COLOR:

- Bronze Anodized
- Clear Anodized

Other: _____

3. GLAZING:

- 1/4" Tempered
- 1" Insulated
- 3/4" Poly - L1
- 1-1/4" Acrylic - L1
- 1-1/4" Poly - L3
- 1-1/4" Acrylic - L3

- Storm Impact Low-E

Other: _____

Key Notes

Unit:

SC-3030 (RIGHT)

Actual Dimension:

36"(W) x 36"(H)

Rough Opening:

36 3/8"(W) x 36 3/8"(H)

Service Opening:

14 1/2"(W) x 29"(H)

Engineer Notes

Date drawn: 5/27/2020

Drawn by: Avasquez

File name: SC-3030.dwg

Page: 1 of 1

Scale: 1:16

NOTE: THIS DRAWING EMBODIES A CONFIDENTIAL PROPRIETY DESIGN ORIGINATED AND OWNED BY QUIKSERV CORP., AND IS SUBMITTED UNDER A CONFIDENTIAL RELATIONS ALL PATENT, MANUFACTURING, SALE RIGHTS REGARDING THE SAME ARE RESERVED EXCEPT TO THE EXTENT RIGHTS ARE EXPRESSLY GRANTED TO OTHERS. THE RECIPIENT AGREES BY ACCEPTING THESE DRAWINGS NOT TO SUPPLY OR DISCLOSE ANY INFORMATION REGARDING THEM TO ANY UNAUTHORIZED PERSONAL.

SIGNATURE: _____

DATE: _____