

General Notes

Actual Dimension:
11"(L) x 10"(W) x 2"(H)

Rough Opening:
8-1/2"(W) x 9-1/2"(L)

TYPICAL QS-1110 DEAL TRAY INSTALLATION:

- 1) QUIKSERV DEAL TRAYS MUST BE INSTALLED LEVEL AND SQUARE TO WORK PROPERLY.
- 2) ANCHOR SCREW, SILICONE OR CLIPS TO BE SUPPLIED BY CONTRACTOR.
- 3) CUT HOLE IN COUNTER TOP 9-1/2" X 8-1/2" SO DEAL TRAY FITS FLUSH TO COUNTER TOP.
- 4) DEAL TRAY CAN BE SILICONED, SCREW APPLIED OR THE USE OF STANDARD KITCHEN SINK CLIPS CAN BE USED TO SECURE DEAL TRAY.
- 5) SILICONE ALL EXTERIOR AND INTERIOR JOINTS.
- 6) ALL OTHER TYPE OF ANCHORING TO BE APPROVED BY CERTIFIED ENGINEER.

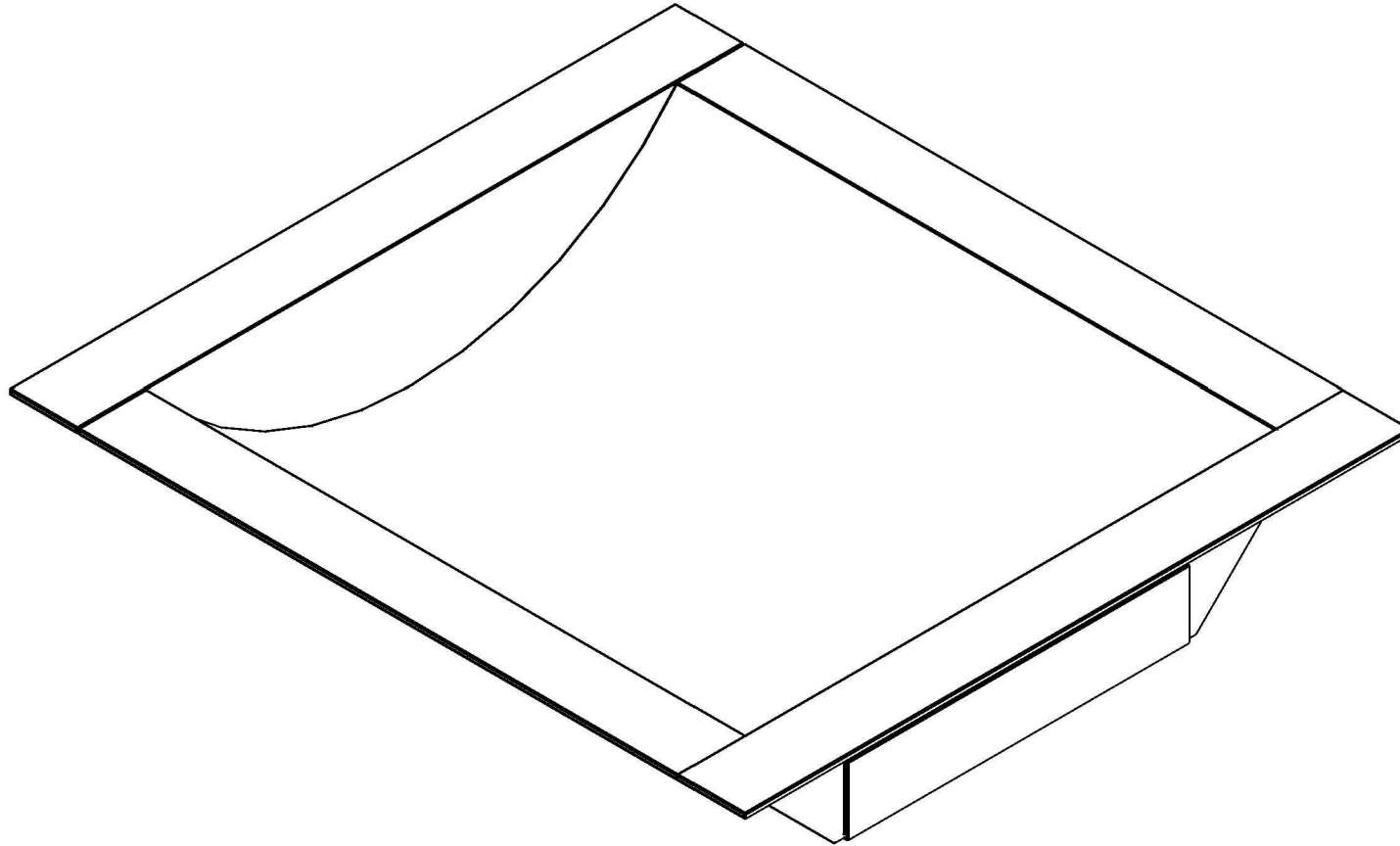

QUIKSERV

11441 BRITTMOORE PARK DR.
HOUSTON, TX., 77041

TITLE:					QS-1110-DEAL TRAY				
Drawing Name					QS-1110-DEAL TRAY INSTALLATION				
DATE	DRAWN BY	SCALE	SHEET	SIZE					
07/15/2016	ESP	1:2	3 of 3	A					

NOTE: THIS DRAWING EMBODIES A CONFIDENTIAL PROPRIETY DESIGN ORIGINATED AND OWNED BY QUIKSERV CORP., AND IS SUBMITTED UNDER A CONFIDENTIAL RELATIONS ALL PATENT, MANUFACTURING, SALE RIGHTS REGARDING THE SAME ARE RESERVED EXCEPT TO THE EXTENT RIGHTS ARE EXPRESSLY GRANTED TO OTHERS. THE RECIPIENT AGREES BY ACCEPTING HIP. THESE DRAWINGS NOT TO SUPPLY OR DISCLOSE ANY INFORMATION REGARDING THEM TO ANY UNAUTHORIZED PERSON.